



## **SHADELUX: VISION BLIND SYSTEM TECHNICAL SPECIFICATIONS**

*Shadelux*  
SYSTEMS

## SHADELUX: VISION BLIND SYSTEM

The Shadelux: Vision Blind system uses our R-40 system as standard. Vision Blinds use two layers of opaque and translucent woven fabric that move independently and slide past each other to give excellent light control throughout the day.



## SYSTEM SPECIFICATION

The Vision blinds use our R-40 system as standard. The R-40 roller blind system is manufactured with grooved 40mm aluminium tubing. Your chosen fabrics are formed and held in the tube with locking tape. The side control units, with acetal sprockets and sprockets guards, is made using glass filled Nylon 6.

Operating chain is No. 10 size in either metal or plastic, ensures reliable performance and chain location enables quick and easy on-site adjustments. Steel brackets are zinc plated and powder coated, allowing for top face or side fixing. If children may be present, chain must be fitted with easy break connectors or a cord tidy device.

A sprung plunger end on opposite end to control unit provide a secure fit and smooth operation.

## SYSTEM OPTIONS

### BOTTOM BAR

Made of aluminium, the fabric slides over the bottom bar tube and the exposed bottom bar slides over the fabric and tube and is then secured with the bottom bar caps and inner bush.

### COLOUR CHOICES

System colours available: white, beige, grey and black. Matching colours available for additional cassettes and bracket covers.

## CASSETTE OPTIONS

The cassette options are manufactured as per the R-40 standard. Options include the specially designed powder coated cassette system with dedicated top, direct or face fix brackets. The user had a choice between a single coloured extrusion, available in White, Beige, Black and Grey, or an aluminium fascia incorporating matching or contrasting fabric used on the blind itself.

## IMPORTANT INFO

### UK MANUFACTURED

Manufactured in the UK, our systems have a two-year guarantee, to ensure consistent quality performance.

### CHILD SAFETY

Fully child safety compliant, based on the relevant elements of BSEN13120. Motorised options are child safe by design

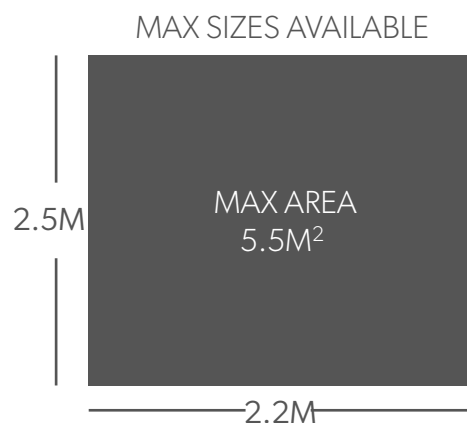

## MAXIMUM RECOMMENDED BLIND SIZES

SYSTEM	FABRIC GROUP	BLIND WIDTH (m) FOR BLIND DROP (m)				MAX HOLDING WEIGHT
		0.5	1.0	1.5	2.0	
SYSTEM 40	up to 200g/m sq	5.0	5.0	5.0	5.0	9lb blind at 6mm deflection
	200 > 320g/m sq	3.75	3.75	3.75	3.75	
	320 > 485g/m sq	5.0	5.0	3.55	2.0	

ALSO AVAILABLE FOR SYSTEM 32

# SHADELUX: VISION SYSTEM DIAGRAMS

## STANDARD SYSTEM

(70MM FULL FASCIA CASSETTE)

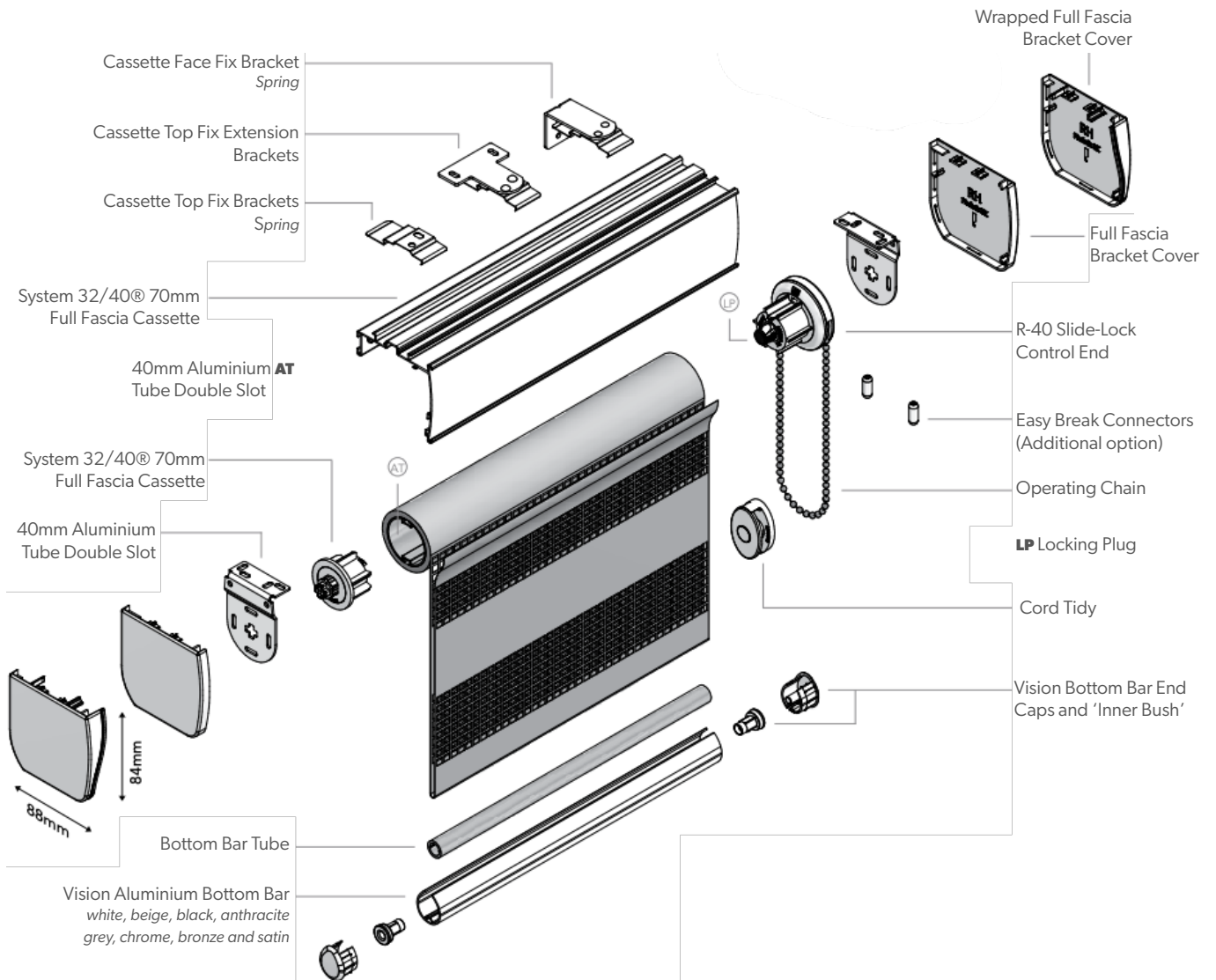

## BRACKET DIMENSIONS

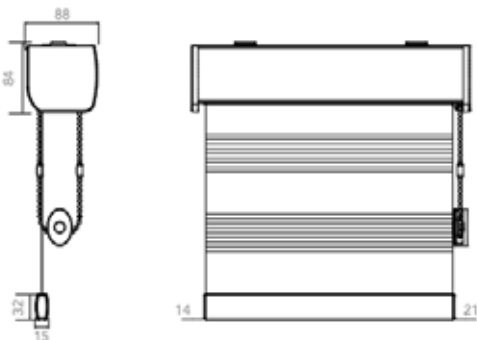

## OPTIONAL CASSETTES

R-32/R-40 Open Cassette  
40mm fascia depth  
white, beige, black, anthracite grey

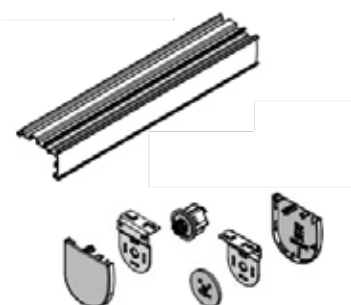

R-32/R-40 Hybrid Closed Cassette  
white, black, anthracite grey

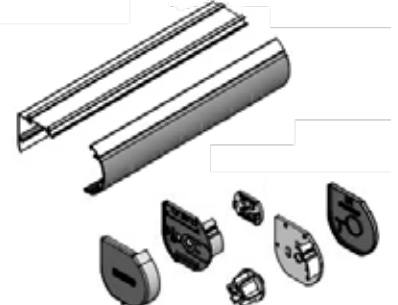

# Shadelux

---

SYSTEMS

01543 279 996

[SALES@HAYWOODSCONTRACTS.CO.UK](mailto:SALES@HAYWOODSCONTRACTS.CO.UK)

21 COBBETT RD, BURNTWOOD  
STAFFORDSHIRE, **WS7 3GL**