

Discount Electric Curtains

Quality. Value. 5 Year Warranty. FREE Delivery

Provided by www.discountelectriccurtains.co.uk



Silent Gliss 5100 Autoglide

Quick Start Guide

1. 5100 Autoglide - System Options

5100B – Base



System 5100B standard control with radio wall switch, comprising of :

Motor 5190

Wall switch 10949

5100R - Remote



System 5100R can be controlled by wall switch or remote control handset comprising of :

Motor 5190

Wall Switch 10949

Handset 10946

5100T - Timer



System 5100T can be controlled by wall switch or timer unit comprising of :

Motor 5190

Wall Switch 10949

Timer 11092

5100TC - Total Control



System 5100TC can be controlled by wall switch, remote handset or Timer unit comprising of :

Motor 5190

Wall Switch 10949

Handset 10946

Timer 11092

2. Setting the Limits (end positions)

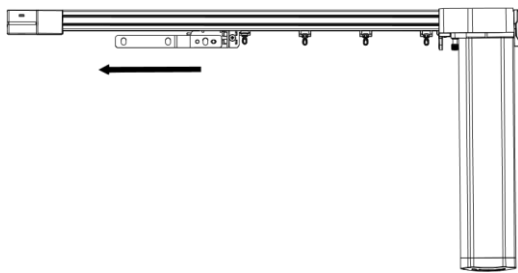
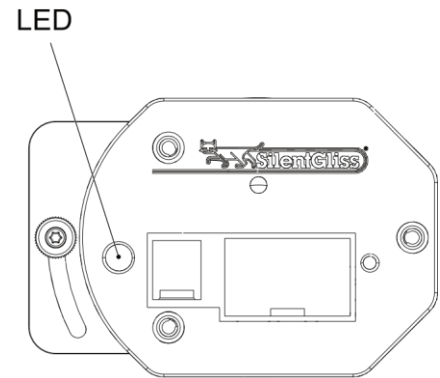
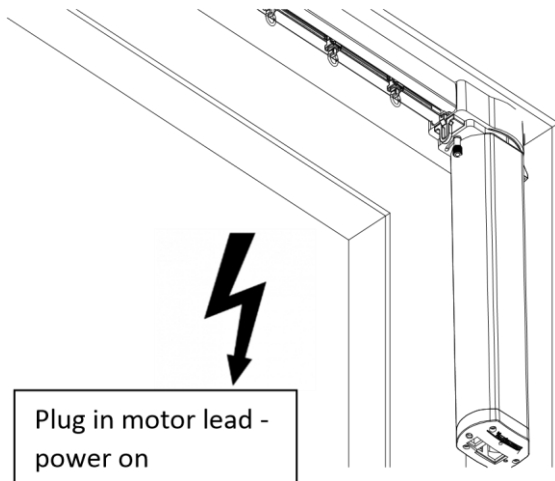

1. Pull curtain in one direction for 15 cm and then let go
2. Curtain moves in this direction until the end
3. LED blinks three times blue
4. First end position is set

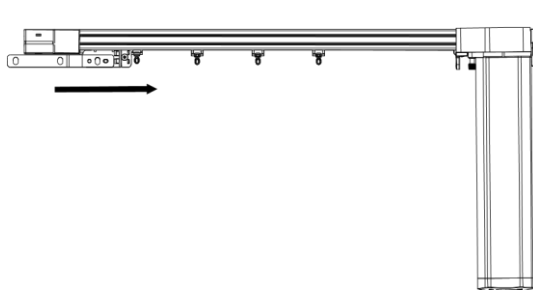

1. Pull curtain in other direction for 15 cm and then let go
2. Curtain moves in other direction until the end
3. LED flashes three times blue
4. Second end position is set

Re-Setting limits (re-positioning end positions)

Changing the limits due to stacking requirements

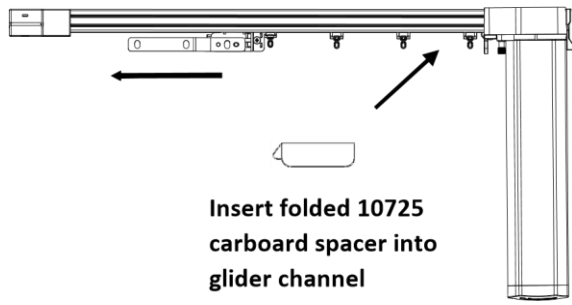

Insert folded 10725 cardboard spacer into glider channel

1. Disconnect Power (Power off) for 10 sec.
2. LED flashes blue twice
3. Insert the cardboard spacer 10725 provided into the glider channel behind

the overlap

arm to pack out to the desired stacking width

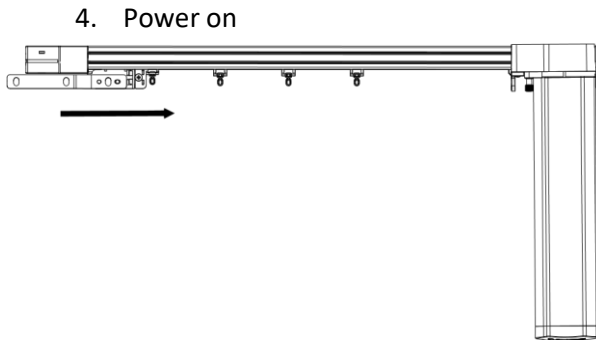

4. Power on

5. Pull curtain in one direction for 15 cm and then let go
6. LED flashes 3 x blue
7. Pull curtain in other direction for 15 cm then let go

8. LED flashes 3 x blue

Please note your 5100 Autoglides are equipped with touch and go and manual override.

Now the limits are set it is possible to operate the curtains by simply pulling the leading edge of either curtain 15 cm in the desired direction, the curtain will then move to the limit in that direction.

If there is a power failure it is possible to move the curtains manually to open and close without damaging the track or motor.

However, it will mean the first movement made in either direction after the power failure will re-set the limits to the extreme ends, here any adjusted limit position set prior to the power failure will be lost. Therefore the adjusted position will need to be reset as per the steps above (Re-Setting limits).

Please note, unplugging the power supply means that the limits need to be re-set as above.

3. Assigning Controls to the motor

All controls are radio control so will need assigning to the motor on the track – for each system option follow the steps below after the limits (end positions) have been set on the motor.

5100B - Base – Wall switch 10949
On the motor

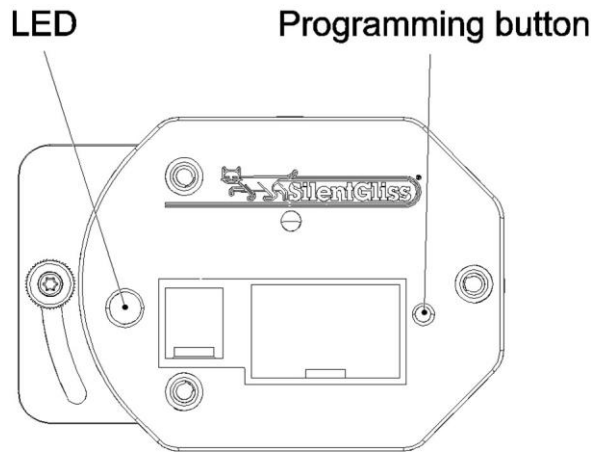

1. Push programming button with a pin for 1 sec
2. LED blinks red
3. Please follow the steps below on the wall switch within the next 10 seconds

On the wall switch

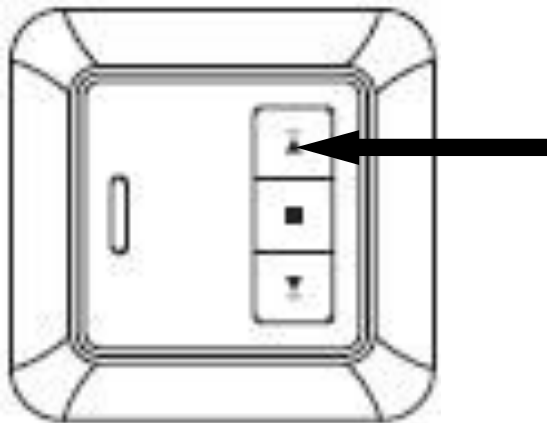

1. Press UP on wall switch
2. LED on motor blinks 3 times blue
3. Wall switch now assigned
4. For any further instructions refer to the instruction manual in wall switch package.

Full instructions for the radio wall switch 10949 are enclosed with the unit.

5100R - Remote – Handset 10946

On motor

LED Programming button

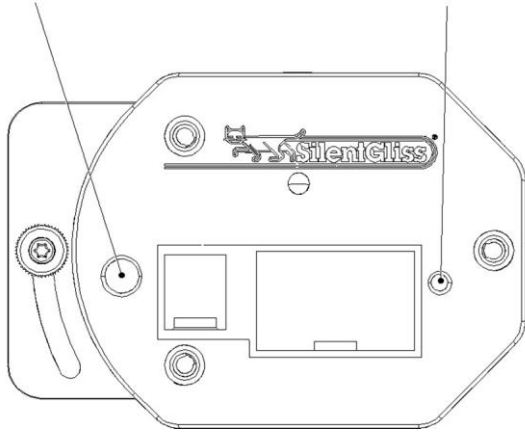

1. Push programming button with a pin for 1 sec.
2. LED blinks red
3. Please follow the steps below on the handset within the next 10 seconds

On Handset 10946

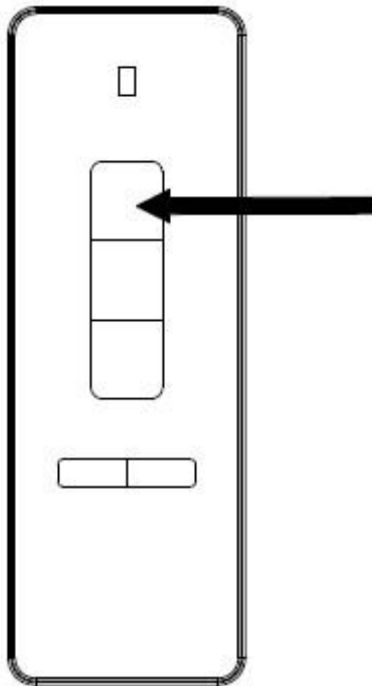

1. Press UP on handset
2. LED on motor blinks 3 times blue
3. Handset now assigned
4. For any further instructions refer to the instruction manual in wall plate package

Full instructions for the handset 10946 are enclosed with the unit.

5100T - Timer – 11092

On timer step - 1



1. To Activate timer press power button on rear of unit approx. 1 sec with a pin.

On Motor

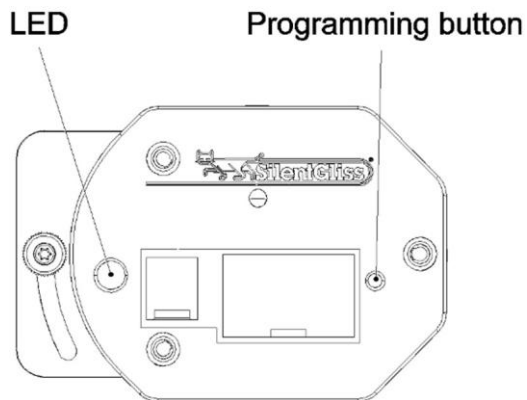

1. Push programming button with a pin for 1 sec
2. LED blinks red
3. Please follow the steps below on the timer within the next 10 seconds whilst the red light is blinking.

On Timer step - 2

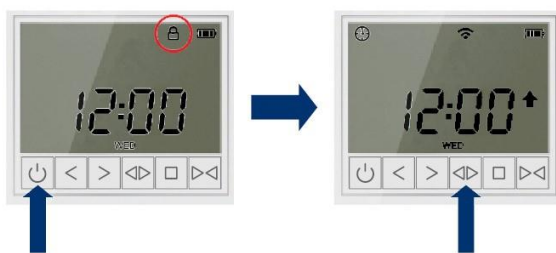

1. Press function button for 3s to enter control window

2. Press open to send signal to motor

The flashing red LED on the motor will now stop.

LED on motor blinks 3 times blue

The timer will now be assigned to the motor.

Note

If at this point pressing open closes the curtains follow the following steps to change the direction.

1. Press stop on the timer for 5 secs
2. LED on motor flashes red slowly
3. Release stop and re-press within 10 secs
4. LED on motor flashes blue x 3 – direction changed

Please note: During operation the timer locks the screen if there is no further operation within 30 seconds.

Screen Display and button functions

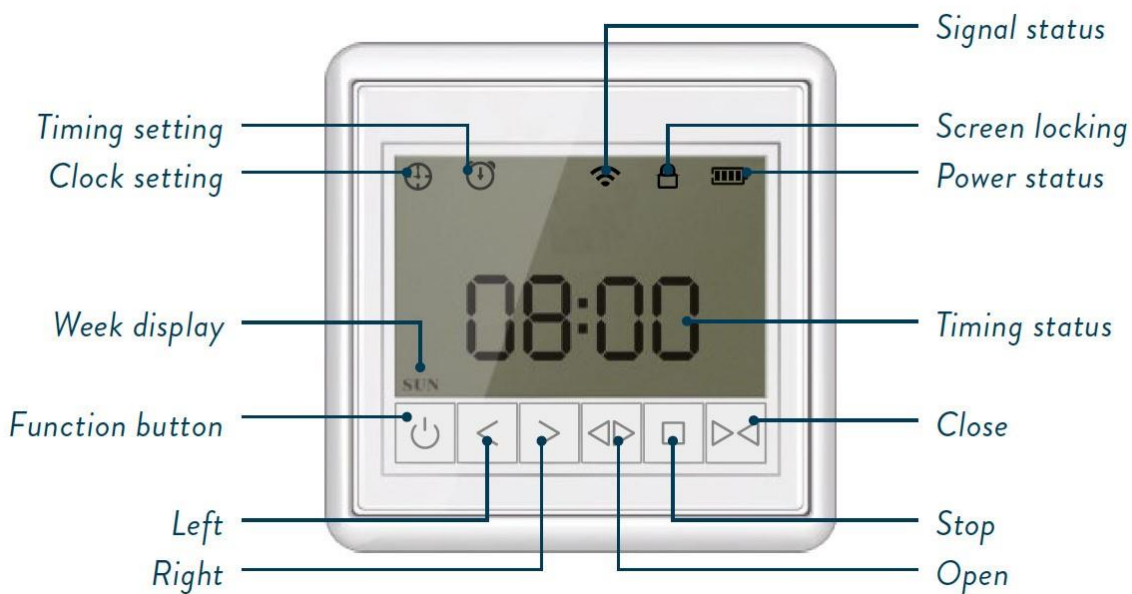

Please see on the following pages for the initial set-up instructions for the of timer for the following functions

The clock, time and day

Timer point set-up for setting the automatic open and close times.

Clock, time / day setting sequence

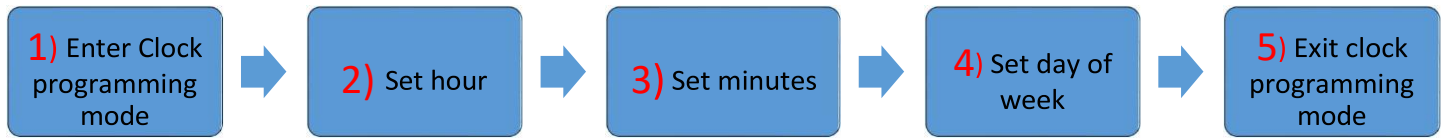

To set the clock time / day settings follow detailed step by step instructions below.

Clock, time / day setting instructions

When setting the hour, minute and day during the programming process, moving to the next function means the last information in the previous function is remembered.



1)  Press for 3 seconds to unlock the screen (ensure the screen unlocks before moving to the next step) padlock symbol disappears the no. 1 appears top left.

 Re-press for 3 seconds again to enter clock programming mode, the clock symbol flashes top left of screen.

2)  Press once to select clock setting programme (defaults to hours).

 Press to move hour forwards,  press to move hour backwards – set hour.

3)  Press once to go to minutes

 Press to move minute forwards,  press to move minute backwards – set minutes.

4)  Press once to go to day

 Press to move day forwards,  press to move day backwards – set day.

5)  Press for 3 seconds to save clock settings and exit clock programming mode return to the control window.

Warning: During normal use and the setting process above the timer screen will lock if the timer is not used or no operation buttons are pressed within 30 seconds. It is now necessary to repeat the processes in steps 1 & 2 above to re-enter the clock setting programme.

Now the clock has been set correctly, proceed to set the automatic open and close times via the timer points as described in the following pages.

Timer operation overview (11092 single channel timer)

The 11092 Single channel timer has 14 timer points for setting the automatic open and close operations of the curtain track – the individual timer points are named - A,B,C,E,F,G,H,I,J,L,O,P,S, and U.

Each of the points are individually programmable – however not all timer points need to be programmed so can be either switched on or left off.

When received from the factory the 11092 timer all time points are pre-set to off, when entering the timer setting window it will default to Timer point A, set off, set to 12.00 noon, set to close and applied to every day of the week.

The individual open or close timer points can be applied to either single or multiple days of the week.

When setting the timer points during the programming process, moving to the next function means the last information in the previous function is remembered.

The following examples in the table below are the most common setting scenario's that can be set using the timing points.

Example	Time Point	Operating days	Operating time (24hr clock)	Function open / close
1	A	Sunday to Saturday	07.30	Open
2	B	Sunday to Saturday	19.00	Close
OR				
3	A	Monday to Friday	07.30	Open
4	B	Monday to Friday	19.00	Close
5	C	Saturday and Sunday	09.30	Open
6	E	Saturday and Sunday	20.00	Close

To set timer point A as per example 1 highlighted in the table above follow detailed step by step instructions on the following pages.

Time point setting sequence

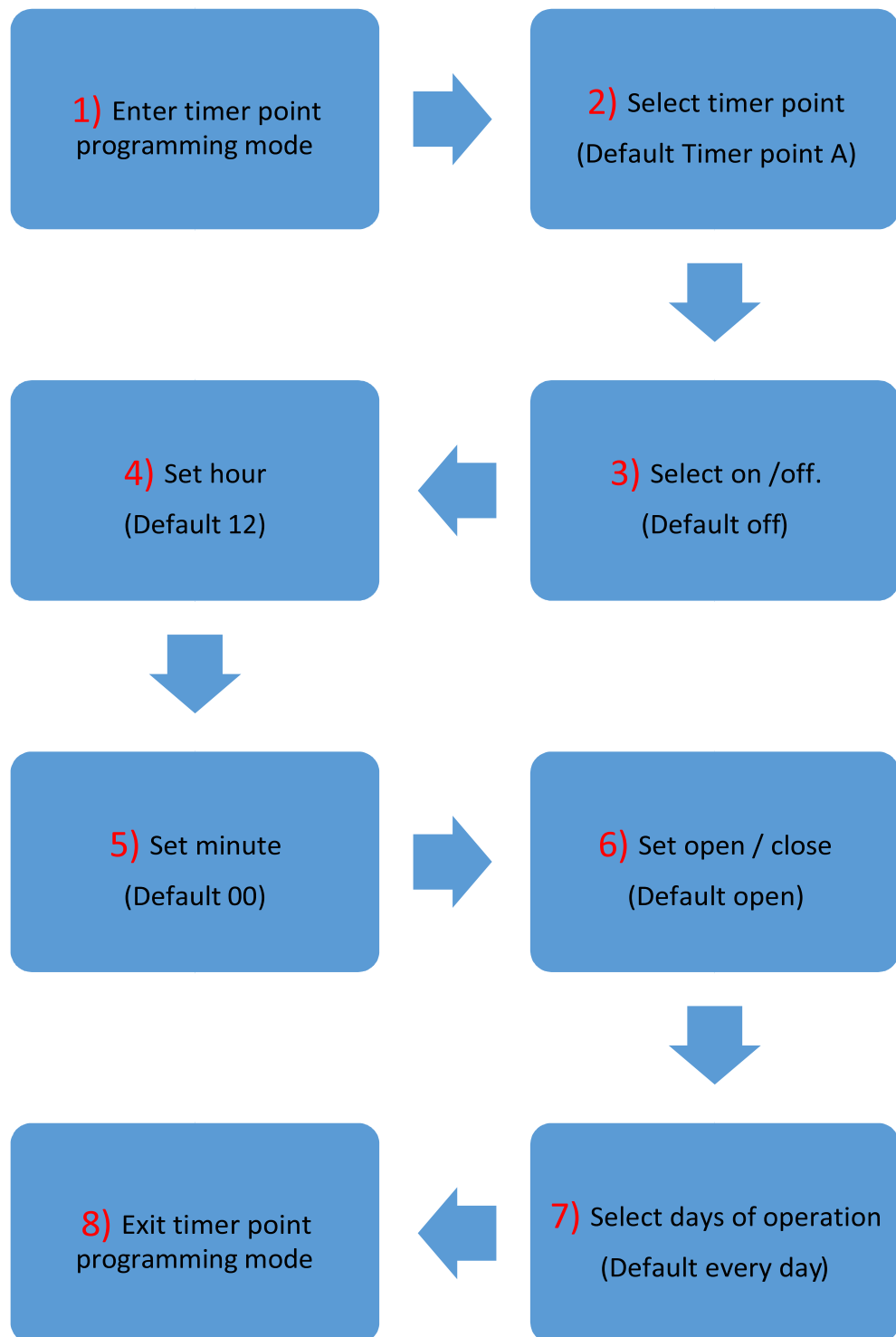



Timer point setting, 1st time set-up (time point A as per example 1 in table on previous page).

1	A	Sunday to Saturday	07.30	Open
---	---	--------------------	-------	------



Note: When setting the timer points during the programming process, moving to the next function means the last information in the previous function is remembered.

1)  Press for 3 seconds to unlock the screen (ensure the screen unlocks before moving to the next step) padlock symbol disappears, the no.1 appears top left.



 Press for 3 seconds to enter programming mode – the clock symbol flashes top left of screen.



 Press once to go to timer mode (alarm clock symbol flashes top left).

2)  Press once to select timer setting programme (pre-set to timer point A) A is flashings.



3)  Press to move to on/off, off flashes press  to turn on.



4)  Press once to go to hour (12 pre-set), press  to move hour backwards to 08.00 (press  to move forward if required).

5)  Press once to go to minutes (00 pre-set), press  to move minutes forward to 30 (press  to move minutes backwards if required).

6)  Press once to go to set open or close (pre-set to close), press  to set open.

7)  Press once to go to days of the week (pre-set to everyday) Sunday will flash – no action is required as default = set to every day.

8) At this point either you have a choice - press  for 3 seconds to save the timer settings and return to control window **OR** move forward to again by pressing  to set a further timer point - A is flashing, press  to move to time point B and programme the functions as per example 2 on table on previous page above

Please note: during the process above on the display  = Open,  = Close

Warning: During normal use and the setting process above the timer screen will lock if the timer is not used or no operation buttons are pressed within 30 seconds. It is now necessary to repeat the processes in steps 1 & 2 above to re-enter the timer setting programme.

Full instructions for setting the timer are enclosed with the 11092 timer unit.

Optional

5100T - Timer – 11093

On Motor

On timer step - 1



1. To Activate timer press power button on rear of unit approx. 1 sec with a pin.

LED Programming button

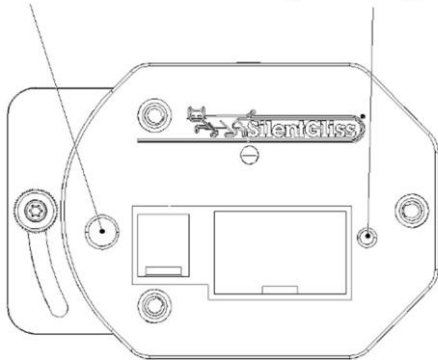

1. Push programming button with a pin for 1 sec
2. LED blinks red
3. Please follow the steps below on the timer within the next 10 seconds.

On Timer



1. Press function button for 3s to enter control window

2. Press Right to select channel 1

3. Press open to send signal to motor

The flashing red LED on the motor will now stop, LED on motor blinks 3 times blue.

The timer will now be assigned to the motor.

Now the clock has been set correctly, proceed to set the automatic open and close times via the timer points as described in the following pages

Timer operation overview (11093 multi-channel timer)

The 11093 multi-channel timer is supplied with 8 timer points for setting the automatic open and close operations of the curtain track – the individual timer points are identified as – 1, 2, 3, 4, 5, 6, 7, and 8.

The timer also has 16 channels which can be assigned to individual or multiple motors, and applied to the timer points above.

Each of the points are individually programmable – however not all timer points need to be programmed so can be either switched on or left off.

When received from the factory the 11093 timer all time points are pre-set to off, so when entering the timer setting window it will default to Timer point 1, set off, set to 12.00 noon, set to close and is applied to every day of the week.

The individual open or close timer points can be applied to either single or multiple days of the week and can be programmed to single or multiple channels.

When setting the timer points during the programming process, moving to the next function means the last information in the previous function is remembered when set.

The following examples in the table below are the most common setting scenario's that can be set using the timing points.

Example	Time Point	Operating days	Operating time (24hr clock)	Channel number	Function open / close
1	A	Sunday to Saturday	07.30	1	Open
2	B	Sunday to Saturday	19.00	1	Close
OR					
3	A	Monday to Friday	07.30	1	Open
4	B	Monday to Friday	19.00	1	Close
5	C	Saturday and Sunday	09.30	2	Open
6	E	Saturday and Sunday	20.00	2	Close





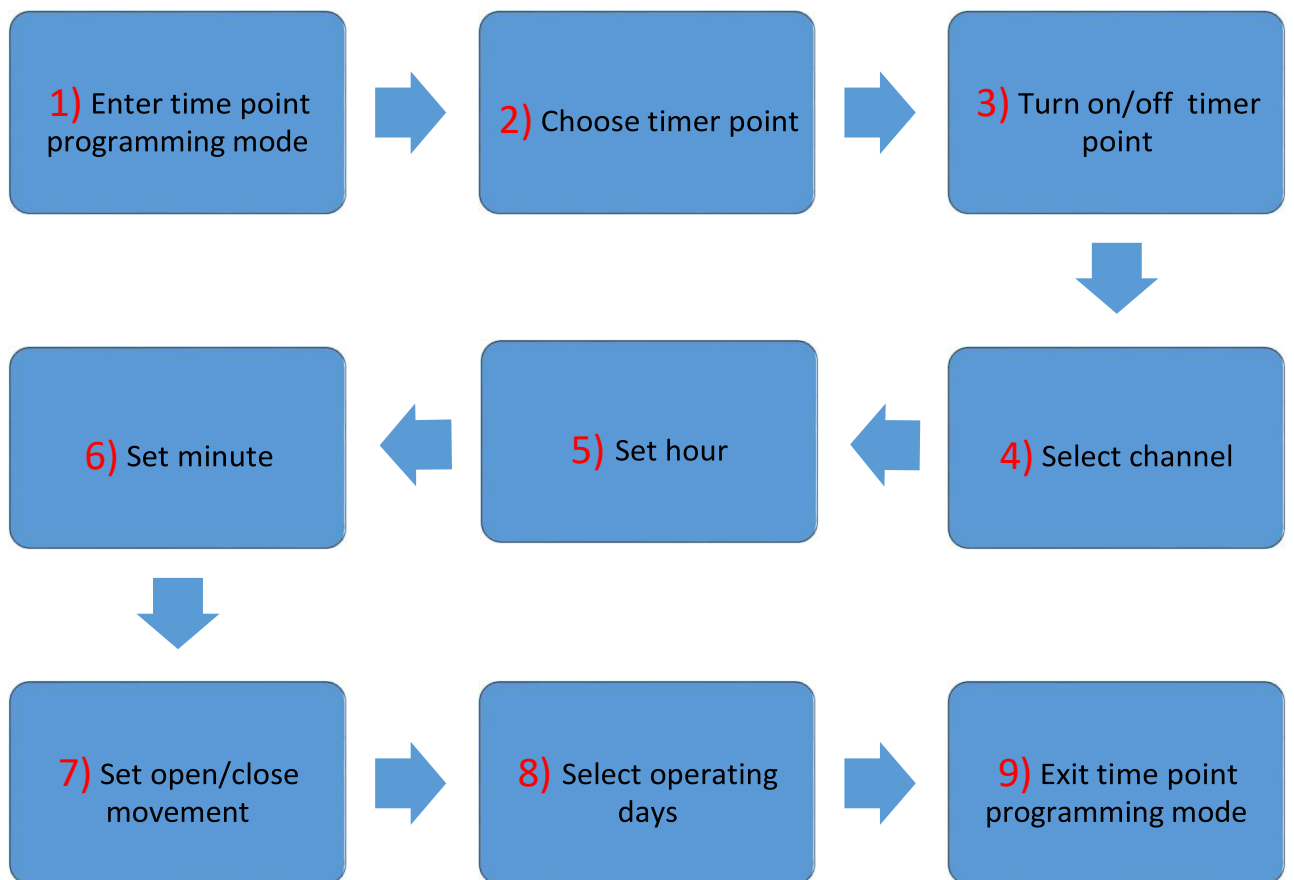

















To set timer point A as per example 1 highlighted in the table above follow detailed step by step instructions on the following pages.



Time point setting sequence



Timer point setting instructions, 1st time set-up (time point A as per example 1 in table on previous page)

Note: When setting the timer points during the programming process, moving to the next function means the last information in the previous function is remembered.

- 1)  Press for 3 seconds to unlock the screen (ensure the screen unlocks before moving to the next step) padlock symbol disappears, the no.1 appears top left.
-  Press for 3 seconds to enter programming mode – the clock symbol flashes top left of screen.
-  Press once to go to timer mode (alarm clock symbol flashes top left).
- 2)  Press once to select timer setting programme (pre-set to timer point A) A is flashing. 3)  Press once to move to on/off, off flashes press  to turn on.
- 4)  Press once to move to Channels, press  /  to move between channels press  to delete or reselect if deleted.
- 5)  Press once to go to hour (12 pre-set), press  to move hour backwards to 08.00 (press  to move forward if you overrun).
- 6)  Press once to go to minutes (00 pre-set), press  to move minutes forward to 30 (press  to move minutes backwards if you overrun).
- 7)  Press once to go to set open or close (pre-set to close), press  to set open.
- 8)  Press once to go to days of the week (pre-set to everyday) Sunday will flash.
- 9) At this point either you have a choice - press  for 3 seconds to save the timer settings and return to control window **OR** move forward to again by pressing  to set a further timer point – A is flashing, press  to move to time point B and programme the functions as per example 2 on table on previous page above.

Please note: during the process above on the display -  = Open,  = Close

Warning: During normal use and the setting process above the timer screen will lock if the timer is not used or no operation buttons are pressed within 30 seconds. It is now necessary to repeat the processes in steps 1 & 2 above to re-enter the timer setting programme.

Full instructions for setting the timer are enclosed with the 11093 timer unit.

The 5100T uses each method of control Wall Plate, Handset and Timer, to assign each please follow the steps as per the instructions above for each unit.

Trouble shooting

Possible fault	Possible cause	Solution
When plugged in the motor will not respond		Ensure the plug is wired correctly, check power is at the socket outlet
When plugged in the motor will not rotate		Re-set end limits – ensure limits are retained
The motor cannot be operated with the switch		Programme the switch to the motor
The motor operates only for a short distance after start up	The track has possibly been assembled incorrectly	Check system, Re-set end limits
Buttons on timer do not respond (all buttons locked)		Remove battery from rear of unit for 5 seconds, replace battery now re-set clock (timer settings are retained).
Curtains do not meet in centre when curtains are hung.		Ensure curtain header is loose enough to allow full movement of the overlap arm.

www.silentgliss.co.uk

Silent Gliss Limited
Pyramid Business Park
Poorhole Lane
Broadstairs
Kent CT10 2PT

Telephone: 01843 863571
Fax: 01843 864503
info@silentgliss.co.uk